

## PRO 76 | Industrial drilling machine

PRO 76 is the newest multifunction drill with Morse Taper No. 3

Electronic Speed Stabilization System (ESSS)

Overload Protection

Integrated Gearbox Housing with Slide

Service friendly

Motor Soft Start

Semi-automatic gib adjustment

Continuous Speed Adjustment

Magnetic Power Adhesion Control (MPAC)

Magnetic Field Shape Control (MFSC)

Swivel Base version available



- Superior features of PRO76 include:
  - purpose designed motor with heavy duty gear box
  - electronic speed control
  - electronic speed stabilization system
  - maintenance friendly design
  - gear box and slide system made as one piece
  - maintenance friendly rail guide system

It is equipped with motor overload protection system, electronic speed control, Electronic Speed Stabilization System (ESSS) – responsible for stabilizing motor's speed under varying loads on the spindle. PRO76 precision and durability are significantly increased thanks to integrated gearbox housing with slide.

Unique semi-automatic gib adjustment system (patent pending) enables simple, fast and always correct fine tuning without any expert knowledge or experience. Replaceable spline at the end of armature shaft eliminates laborious and expensive armature maintenance. Compact design allows for drilling very close to vertical surface.

PRO 76 is also equipped with electromagnetic base featuring magnetic field shape control system (MFSC) and magnetic power adhesion control module (MPAC), which detects adhesive force of electromagnetic base and protects both the machine and the operator from work on too thin workpieces.

Standard shipping set of PRO 76 includes MT3 Arbor with 19mm (3/4") Weldon Bore that accepts cutters up to 60mm diameter. Optional MT3 Arbor with 32mm (1-1/4") Weldon Bore for cutters of larger diameters is available.



Core drill  
max 76 mm



Twist drill  
max 32 mm



Spindle  
MT3



Depth of cut  
76 mm



Stroke  
225 mm



Speed 80-160,  
210-420 rpm



Motor Power  
1650 W



Weight  
27 kg

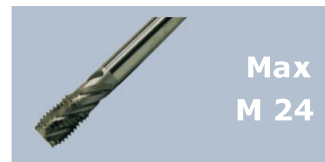

**PRO 76 - Technical specification**

Motor Speed (under load)	80÷160; 210÷420 rpm
Motor Power	1.650 W
Weight	27 kg (58 lbs 4 oz)
Max milling capacity	Ø 76 mm (3'')
Max drilling capacity	Ø 32 mm (1-1/4'')
Max countersinking	Ø 63 mm (2-1/2'')
Max tap size	M24 (tapping attachment required)
Stroke	225 mm (8-7/8'')
Max depth of cut	76 mm (3'')
Voltage	115V/60Hz or 230V 50/60Hz
Power consumption	1.800 W
Overload protection	yes
ESSS	yes
Continuous speed adjustment	yes
Semi-automatic gib adjustment	yes
MPAC	yes
MFSC	yes
Magnetic clamping force	1988 kG (19500 N) /25mm, Ra=1,25/
Magnet Base Dimensions	110 x 220 x 56 mm 4-5/16 x 8-11/16 x 2-3/16 (")
Min. Workpiece Thickness	10 mm (3/8'')
Swivel base	±15°; ±15mm (± 9/16'')
Spindle	MT3
Tool holder	19mm (3/4'') or 32mm (1-1/4'') Weldon

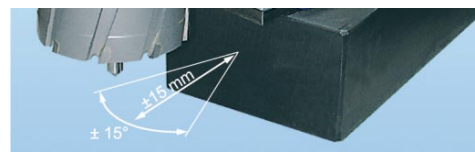

Swivel base in version PRO 76+

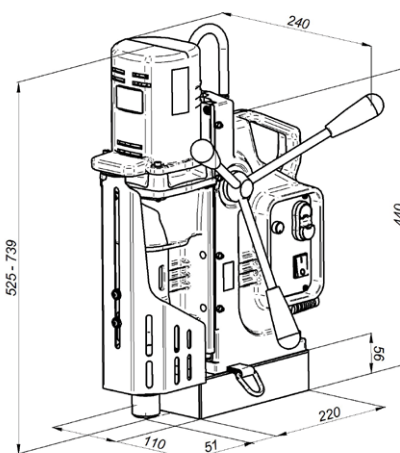

**Standard shipping set:**

- Magnetic Base Drilling Machine
- Metal Box
- MT3 Arbor with 19mm Bore - Through Spindle Continuous Cooling
- Swarf Shield/Cutter Guard
- Coolant Bottle Assembly, Safety Chain with Snap Hook, Set of Tools with Wedg
- Operator's Manual (English)
- Standard shipping weight – 40 kg (86 lbs 5 oz)

**Selected additional accessories:**

- UCW-0191-00-00-00 Through Spindle Continuous Cooling Arbor MT3-32 Weldon Bore
- UCW-0285-03-00-02-0 Quick Change Continuous Cooling Arbor MT3- 19 Weldon
- PDS-0111-03-00-01-0 DMP0501 Pipe Attachment

All information is subject to change without notice. 1508



PROMOTECH Sp. z o.o.  
ul. Elewatorska 23/1, 15-620 BIAŁYSTOK, POLAND  
tel. (+48 85) 678 34 05, fax (+48 85) 662 78 77  
marketing@promotech.eu www.promotech.eu

Your local dealer:

