

# OXY-FUEL/PLASMA CUTTING

# MODULAR TRACK CARRIAGE

# TRACK WELDING & CUTTING

smart tools  
for heavy tasks

## WELDING & CUTTING TRACTORS

### DRAGON

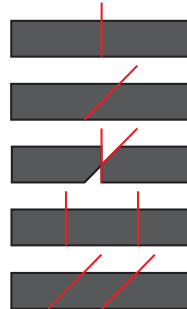

Machine quality cutting and beveling up to 45° with one or 2 torches.

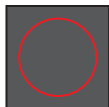

Circle cutting is available as option.



High speed plasma cutting and beveling

### DRAGON HS

### RAIL BULL 2



Linear oscillation with trapezoid, triangle and straight line paths



Ring tracks from 200 mm up to 3000 mm OD



Continuous welding



Horizontal speed 10-300 cm/min



Vertical speed 10-300 cm/min



Stitch welding



Min. path convex radius 5000 mm



Weight 12 kg

### RAIL BULL WITH OSCILLATION

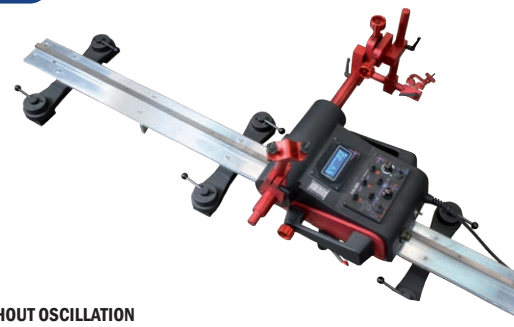

### RAIL BULL WITHOUT OSCILLATION



Linear oscillation with trapezoid, triangle and straight line paths  
Rail Bull with oscillation



Oxy-fuel cutting  
Rail Bull without oscillation



Continuous welding



Horizontal speed 0-120 cm/min



Vertical speed 0-110 cm/min



Min. path convex radius 5000 mm



Weight  
20 kg Rail Bull with oscillation  
18 kg Rail Bull w/o oscillation

smart tools for heavy tasks

## MULTIPURPOSE TRACK SYSTEM

PROMOTECH is an innovation driven manufacturer of professional power tools and welding automation equipment.

DRILLING



BEVELLING



WELDING



CUTTING



More information about Promotech's Vacuum System configurations and components is available at company website [www.promotech.eu](http://www.promotech.eu)



### PROMOTECH SP. Z O.O.

ul. Elewatorska 23/1, 15-620 BIAŁYSTOK, POLAND  
tel. (+48 85) 678 34 95, fax (+48 85) 662 78 77  
[marketing@promotech.eu](mailto:marketing@promotech.eu) [www.promotech.eu](http://www.promotech.eu)  
[www.doorframewelding.com](http://www.doorframewelding.com)

PROMOTECH®



[www.promotech.eu](http://www.promotech.eu)



Made in Poland according to the highest quality standards



CE-certified



Quality Management System complies with the requirements of ISO 9001:2008









## GECKO BATTERY



## GECKO HS













## GECKO

-  Continuous welding
-  Dual torch welding
-  Horizontal speed 0-110 cm/min  
5-220 cm/min Gecko HS
-  Vertical speed 0-100 cm/min
-  Min. path convex radius 1000 mm
-  Min. path concave radius 1000 mm
-  Weight 8 kg

## LIZARD



## OSCILLATOR

-  Programming device up to 40 welding programs
-  Pendulum oscillation
-  Continuous welding
-  Stitch welding
-  Dual torch welding
-  Horizontal speed 0-120 cm/min
-  Vertical speed 0-110 cm/min
-  Min. path convex radius 1500 mm
-  Min. path concave radius 1500 mm
-  Weight 14 kg

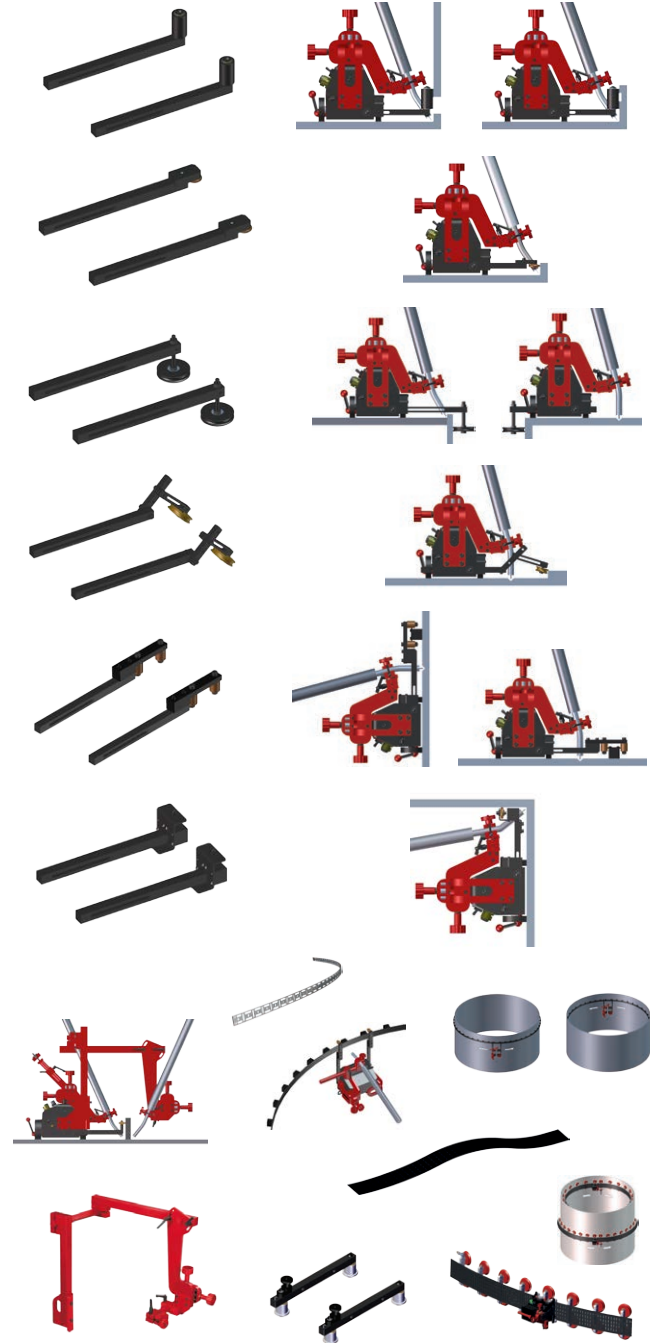

Mitglied im **DVS**  
DVS – Deutscher Verband für Schweißen  
und verwandte Verfahren e.V.