

PRO-76T | MULTIFUNCTIONAL DRILLING & TAPPING MACHINE

PRO-76T is multifunction machine with Morse Taper No. 3 that can perform also tapping jobs thanks to the left and right rotations. The drill is equipped with motor overload protection system and continuous speed adjustment, which works in two speed ranges. Additionally, it has a state of the art Electronic Speed Stabilization System (ESSS), responsible for stabilizing motor's speed under varying loads on the spindle. Its precision and durability are significantly increased thanks to the one gearbox housing and slide.

Unique semi-automatic gib backlash adjustment (Promotech's patent pending) enables simple, fast and correct adjustments without any expert knowledge or experience. Replaceable spline at the end of armature shaft eliminates laborious and expensive armature maintenance.

PRO-76T is equipped with electromagnetic base featuring magnetic field shape control system (MFSC) and magnetic power adhesion control module (MPAC), which detects adhesive force of electromagnetic base and protects both the machine and the operator from work on too thin workpieces.

Standard shipping set of PRO 76T includes MT3 Arbor with 3/4" (19 mm) Weldon Bore that accepts cutters up to 60 mm (2-5/16") diameter. Optional MT3 Arbor with 1-1/4" (32 mm) Weldon Bore for cutters of larger diameters is available.

PRO-76T can also be ordered with a swivel base as PRO 76T+.

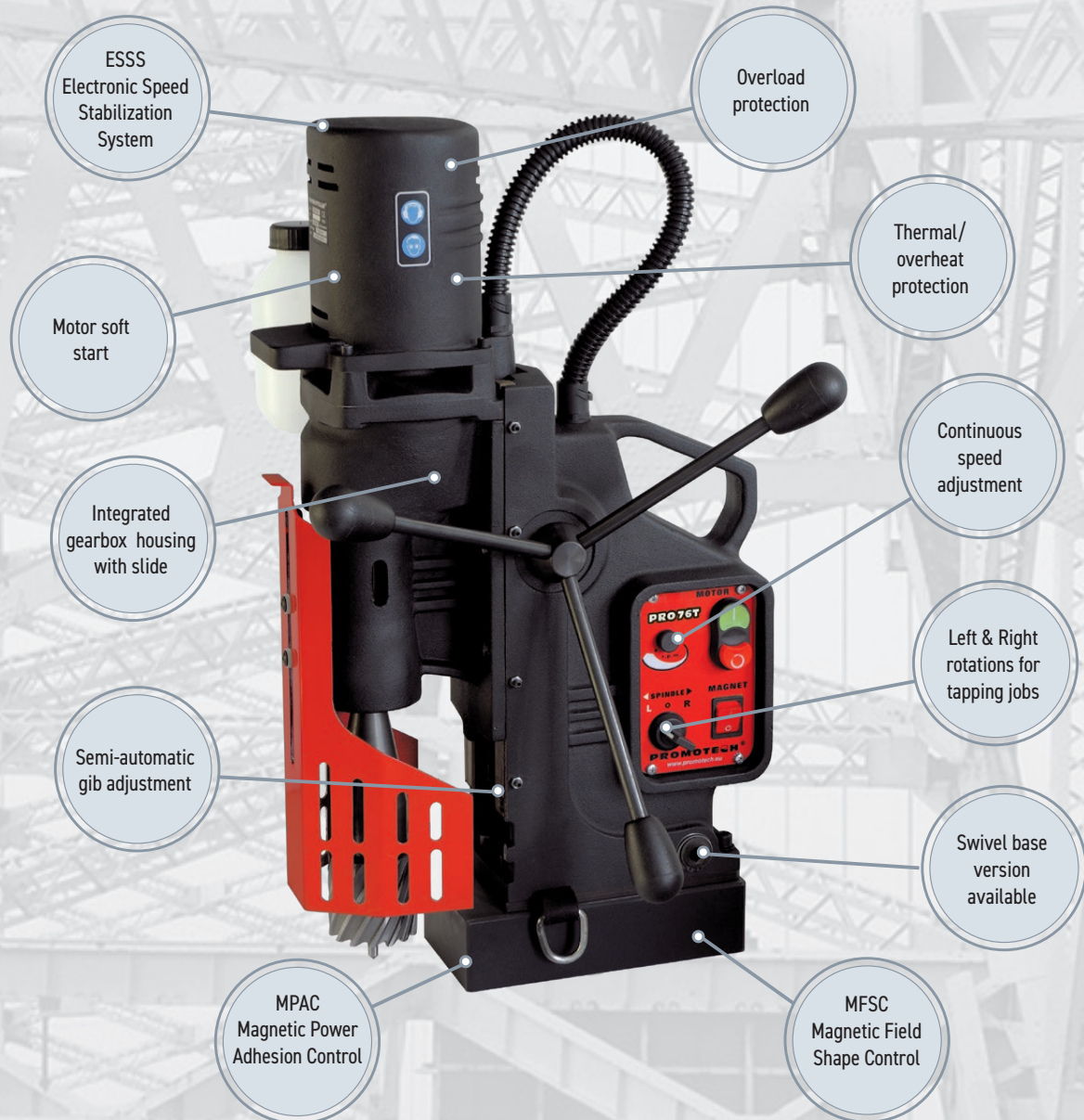

										
Core drill max 76 mm	Twist drill max 32 mm	Thread cutting M24	Spindle MT3	Depth of cut 76 mm	Stroke 225 mm	Speed 80-160, 210-420 rpm	Power 1800 W	Weight 27 kg	Thermal/ overheat protection	Overload protection

Promotech introduces quick change tapping system including:



- TC - Tapping chucks with securing nut
- TA - Tapping Adapters for through holes
- TASC - Tapping Adapters Safety Clutch for blind holes
- RA - Reduction Adapters

PRO-76T - Available tapping configurations

Tapping tool	Tapping chucks		
	MT3-19	MT3-31	MT3-48
M8	TA-1 or TASC-1	TA-1 or TASC-1 along with optional RA 2/1	TA-1 or TASC-1 along with optional RA 3/1
M10			
M12			
M8	TA-2 or TASC-2		TA-2 or TASC-2 along with optional RA 3/2
M10			
M12			
M14			
M16			
M18			
M20	TA-3 or TASC-3		
M14			
M16			
M18			
M20			
M22, M24			

Standard tapping configuration

Optional tapping configuration

Promotech quick change tapping system accessories suitable for PRO-76T drilling machine:

TC - Tapping chucks with securing nuts

Product Code	Type	Description
OPR-0584-11-00-00-1	MT3-19	Tapping chuck MT3 x 19 mm
OPR-0584-08-00-00-1	MT3-31	Tapping chuck MT3 x 31 mm
OPR-0584-02-00-00-1	MT3-48	Tapping chuck MT3 x 48 mm



Tapping chuck equipped with securing nut protects tapping tool against pull out



Shipping set of tapping chuck incl. HD-CUT OIL1

RA - Reduction Adapters

Product Code	Type	Description
RDC-000008	RA 2/1	Reduction Adapter 2/1 (31 mm / 19 mm)
RDC-000009	RA 3/1	Reduction Adapter 3/1 (48 mm / 19 mm)
RDC-000010	RA 3/2	Reduction Adapter 3/2 (48 mm / 31 mm)



Through hole tapping up to M24

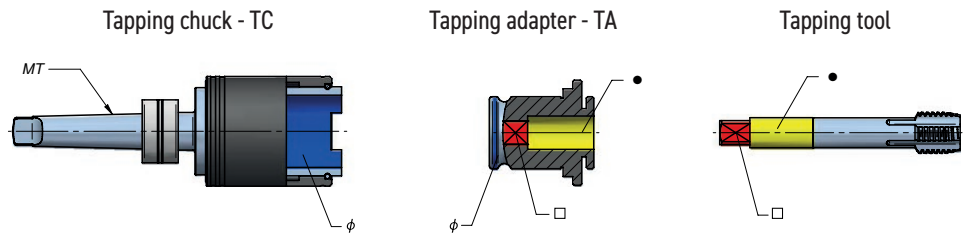

TA - Tapping Adapters

Product Code	Type	Description	∅ [mm]	Tap size	● [mm]	□ [mm]
WKL-000069	TA-1	Tapping Adapter 19 mm x M8	19	M8	8	6,2
WKL-000070	TA-1	Tapping Adapter 19 mm x M10	19	M10	10	8
WKL-000071	TA-1	Tapping Adapter 19 mm x M12	19	M12	9	7
WKL-000072	TA-2	Tapping Adapter 31 mm x M8	31	M8	8	6.2
WKL-000073	TA-2	Tapping Adapter 31 mm x M10	31	M10	10	8
WKL-000074	TA-2	Tapping Adapter 31 mm x M12	31	M12	9	7
WKL-000075	TA-2	Tapping Adapter 31 mm x M14	31	M14	11	9
WKL-000076	TA-2	Tapping Adapter 31 mm x M16	31	M16	12	9
WKL-000077	TA-2	Tapping Adapter 31 mm x M18	31	M18	14	11
WKL-000078	TA-2	Tapping Adapter 31 mm x M20	31	M20	16	12
WKL-000079	TA-3	Tapping Adapter 48 mm x M14	48	M14	11	9
WKL-000080	TA-3	Tapping Adapter 48 mm x M16	48	M16	12	9
WKL-000081	TA-3	Tapping Adapter 48 mm x M18	48	M18	14	11
WKL-000082	TA-3	Tapping Adapter 48 mm x M20	48	M20	16	12
WKL-000083	TA-3	Tapping Adapter 48 mm x M22/M24	48	M22, M24	18	14.5

Blind hole tapping up to M24

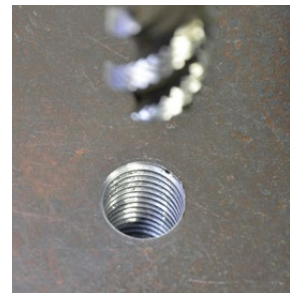
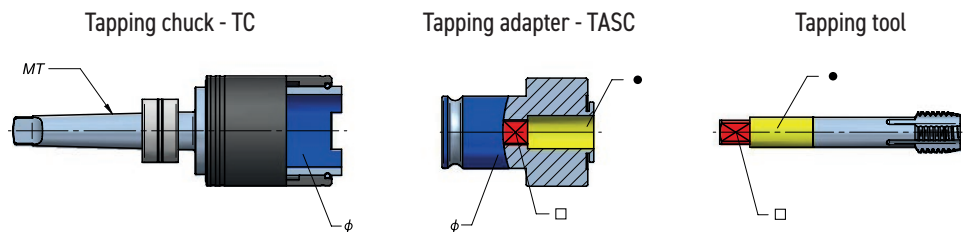

TASC - Tapping Adapters Safety Clutch

Product Code	Type	Description	∅ [mm]	Tap size	● [mm]	□ [mm]
WKL-000095	TASC-1	Tapping Adapter with Safety Clutch 19 mm x M8	19	M8	8	6,2
WKL-000098	TASC-1	Tapping Adapter with Safety Clutch 19 mm x M10	19	M10	10	8
WKL-000099	TASC-1	Tapping Adapter with Safety Clutch 19 mm x M12	19	M12	9	7
WKL-000100	TASC-2	Tapping Adapter with Safety Clutch 31 mm x M8	31	M8	8	6.2
WKL-000101	TASC-2	Tapping Adapter with Safety Clutch 31 mm x M10	31	M10	10	8
WKL-000102	TASC-2	Tapping Adapter with Safety Clutch 31 mm x M12	31	M12	9	7
WKL-000103	TASC-2	Tapping Adapter with Safety Clutch 31 mm x M14	31	M14	11	9
WKL-000104	TASC-2	Tapping Adapter with Safety Clutch 31 mm x M16	31	M16	12	9
WKL-000105	TASC-2	Tapping Adapter with Safety Clutch 31 mm x M18	31	M18	14	11
WKL-000106	TASC-2	Tapping Adapter with Safety Clutch 31 mm x M20	31	M20	16	12
WKL-000107	TASC-3	Tapping Adapter with Safety Clutch 48 mm x M14	48	M14	11	9
WKL-000108	TASC-3	Tapping Adapter with Safety Clutch 48 mm x M16	48	M16	12	9
WKL-000109	TASC-3	Tapping Adapter with Safety Clutch 48 mm x M18	48	M18	14	11
WKL-000110	TASC-3	Tapping Adapter with Safety Clutch 48 mm x M20	48	M20	16	12
WKL-000111	TASC-3	Tapping Adapter with Safety Clutch 48 mm x M22/M24	48	M22, M24	18	14.5



Max
Ø 76 mm
(3")



Max
Ø 32 mm
(1-1/4")



Max
Ø 63 mm
(2-1/2")



Max
M24
(G 3/4")

PRO-76T TECHNICAL SPECIFICATION

Motor Speeds (under load)	80÷160; 210÷420 rpm
Power	1800 W
Weight	27 kg (58 lbs 4 oz)
Max milling capacity	76 mm (3")
Max drilling capacity	32 mm (1-1/4")
Max countersinking	63 mm (2-1/2")
Max Tap size	M24
Stroke	225 mm (8-7/8")
Max depth of cut	76 mm (3")
Voltage	1~ 110-120 V, 50-60 Hz 1~ 220-240 V, 50-60 Hz
Thermal/overheat protection	yes
Overload protection	yes
ESSS (Electronic Speed Stabilization System)	yes
Continuous Speed Adjustment	yes
Semi-automatic gib adjustment	yes
MPAC (Magnetic Power Adhesion Control)	yes
MFSC (Magnetic Field Shape Control)	yes
Magnetic clamping force	1988 kgf (19500 N) /25 mm, Ra=1,25/
Magnet Base Dimensions	110 x 220 x 56 mm; (4-5/16 x 8-11/16 x 2-3/16")
Swivel base (PRO76T+)	± 15°; ± 15 mm (± 9/16")
Min. Workpiece Thickness	10 mm (3/8")
Spindle	MT3
Tool holder	19 mm (3/4") or 32 mm (1-1/4") Weldon
Product Code 220-240 V, 50-60 Hz	WRT-0473-10-20-00-0
Product Code 220-240 V, 50-60 Hz w. swivel base	WRT-0473-10-20-00-1
Product Code 110-120 V, 50-60 Hz	WRT-0473-10-10-00-0
Product Code 110-120 V, 50-60 Hz w. swivel base	WRT-0473-10-10-00-1

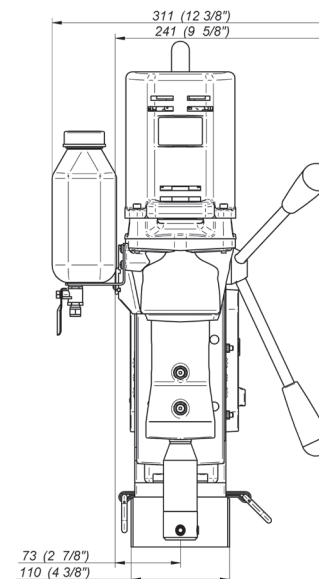
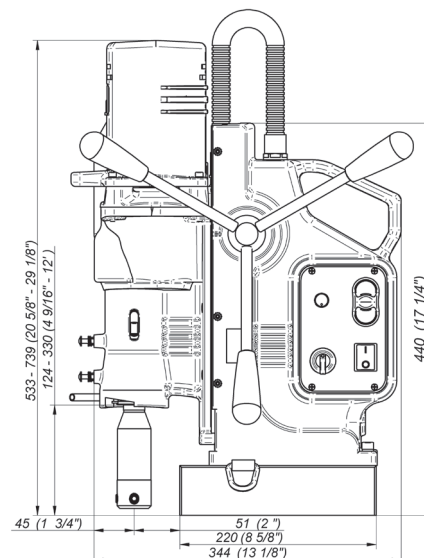

Standard shipping set:

- Magnetic Base Drilling Machine
- Metal Box
- MT3 Arbor with 19 mm Bore - Through Spindle Continuous Cooling
- Swarf Shield/Cutter Guard
- Coolant Bottle Assembly, Safety Chain with Snap Hook, Set of Tools with Wedge
- Operator's Manual
- Standard shipping weight - 40 kg (86 lbs 5 oz)

Selected additional accessories:

- UCW-0191-00-00-00-0 Through Spindle Continuous Cooling Arbor MT3-32 Weldon Bore
- UCW-0285-03-00-02-0 Quick Change Continuous Cooling Arbor MT3- 19 Weldon
- PDS-0111-03-00-01-0 DMP0501 Pipe Attachment
- UKL-0440-16-00-00-0 Pressure Coolant System 21

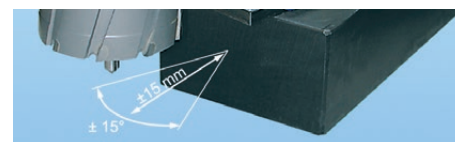

Swivel base in version PRO-76T+

All information is subject to change without notice. 21.12



PROMOTECH Sp. z o.o.
ul. Elewatorska 23/1, 15-620 BIAŁYSTOK, POLAND
tel. (+48 85) 678 34 05, fax (+48 85) 662 78 77
marketing@promotech.eu www.promotech.eu

Your local dealer:

